



**Just Chill**  
DRINKS CO.  
LLC

# KARAK - MODEL iMIX®-3 Black

## SPECIFICATIONS

**Product #:** 36900.0000, **Water Access:** Plumbed,  
**Finish:** Black, **Hoppers:** Three, **Door:** Side Hinge,  
**Dispense:** Push Button

## ELECTRICAL REQUIREMENTS & CAPACITY

220 - 240 VAC 50/60 Hz, Single Phase; 3 Wire,  
20 A Circuit or 3000 – 3500 W

**8oz Cups/Hr 236ml Cups/Hr** - 72

**Input H<sub>2</sub>O Temp** - 60°F (15.5°C)

**Phase** - 1

**# Wires Plus Ground** - 2

**Hertz** - 50/60

## PLUMBING REQUIREMENTS

**PSI** - (20 - 100)

**KPA** - (138 - 689)

**FITTING SUPPLIED** - 1/4" Male Flare Fitting

**WARNING:** This product can expose you to chemicals including Bisphenol A (BPA), which is known to the State of California to cause birth defects or other reproductive harm. For more information go to [www.P65Warnings.ca.gov](http://www.P65Warnings.ca.gov)



## FEATURES AND BENEFITS

- 4.4gal (16.7L) hot water tank to meet peak serving times
- Alphanumeric display communicates advertising messages, machine status and technical support contact information
- Auger motors with RPM feedback monitoring assure consistent flavors and profits by controlling powder dosing
- Capacity: Three 8lb (3.6kg) hoppers
- Cup clearance at 7.25" (18.4cm) to accommodate popular cup sizes [adjustable to 8.12" (20.6cm)]
- Front of machine access to tank drain, dump valves, auger and whipper motors and control board for easy service set up and calibration
- High speed heavy-duty whipper for complete product mixing
- Low product detection system alerts audibly and with message on display when hoppers are low
- High efficiency LED lighted front graphics for merchandising
- Night mode to prevent pilferage • Spring-loaded, all metal auger drive system for easy hopper installation



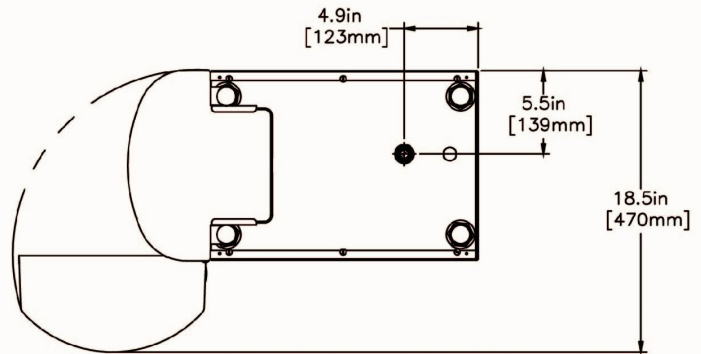
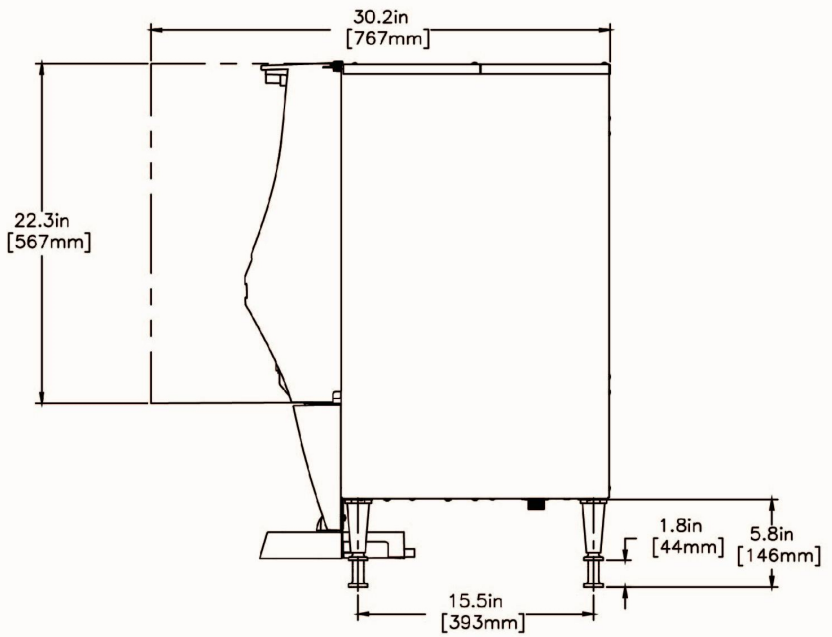
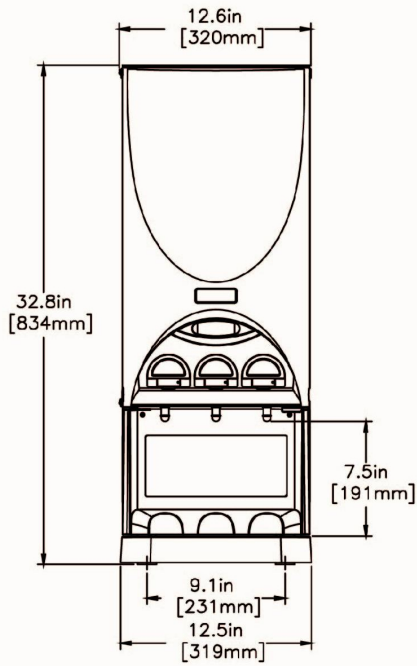

	Unit			Shipping				
	Height	Width	Depth	Height	Width	Depth	Weight	Volume
English	32.8 in.	12.6 in.	24.0 in.	41.7 in.	17.1 in.	29.5 in.	101.765 lbs	12.144 ft <sup>3</sup>
Metric	83.3 cm	32.0 cm	61.0 cm	105.9 cm	43.3 cm	74.9 cm	46.161 kgs	0.344 m <sup>3</sup>



BUNN® reserves the right to change specifications and product design without notice. Such revisions do not entitle the buyer to corresponding changes, improvements, additions or replacements for previously purchased equipment. For most current specifications and other info visit [bunn.com](http://bunn.com).

Last Updated:  
10/15/2020